

Protective clothing — Protection against heat and flame — Method of test for limited flame spread

The European Standard EN ISO 15025:2002 has the status of a
British Standard

ICS 13.340.10

NO COPYING WITHOUT BSI PERMISSION EXCEPT AS PERMITTED BY COPYRIGHT LAW

National foreword

This British Standard is the official English language version of EN ISO 15025:2002. It is identical with ISO 15025:2000. It supersedes BS EN 532:1995 which is withdrawn.

The UK participation in its preparation was entrusted by Technical Committee PH/3, Protective clothing, to Subcommittee PH/3/2, Protection against heat and flame, which has the responsibility to:

- aid enquirers to understand the text;
- present to the responsible international/European committee any enquiries on the interpretation, or proposals for change, and keep the UK interests informed;
- monitor related international and European developments and promulgate them in the UK.

A list of organizations represented on this subcommittee can be obtained on request to its secretary.

Cross-references

The British Standards which implement international or European publications referred to in this document may be found in the *BSI Catalogue* under the section entitled "International Standards Correspondence Index", or by using the "Search" facility of the *BSI Electronic Catalogue* or of British Standards Online.

This publication does not purport to include all the necessary provisions of a contract. Users are responsible for its correct application.

Compliance with a British Standard does not of itself confer immunity from legal obligations.

This British Standard, having been prepared under the direction of the Health and Environment Sector Policy and Strategy Committee, was published under the authority of the Standards Policy and Strategy Committee on 22 November 2002

Summary of pages

This document comprises a front cover, an inside front cover, the EN ISO title page, the EN ISO foreword page, the ISO title page, pages ii to v, a blank page, pages 1 to 16, the Annex ZA page and a back cover.

The BSI copyright date displayed in this document indicates when the document was last issued.

Amendments issued since publication

Amd. No.	Date	Comments

© BSI 22 November 2002

ISBN 0 580 40787 X

English version

Protective clothing - Protection against heat and flame - Method
of test for limited flame spread (ISO 15025:2000)

Vêtements de protection - Protection contre la chaleur et
les flammes - Méthode d'essai pour la propagation de
flamme limitée (ISO 15025:2000)

Schutzkleidung - Schutz gegen Hitze und Flammen -
Prüfverfahren für die begrenzte Flammenausbildung (ISO
15025:2000)

This European Standard was approved by CEN on 11 April 2002.

CEN members are bound to comply with the CEN/CENELEC Internal Regulations which stipulate the conditions for giving this European Standard the status of a national standard without any alteration. Up-to-date lists and bibliographical references concerning such national standards may be obtained on application to the Management Centre or to any CEN member.

This European Standard exists in three official versions (English, French, German). A version in any other language made by translation under the responsibility of a CEN member into its own language and notified to the Management Centre has the same status as the official versions.

CEN members are the national standards bodies of Austria, Belgium, Czech Republic, Denmark, Finland, France, Germany, Greece, Iceland, Ireland, Italy, Luxembourg, Malta, Netherlands, Norway, Portugal, Spain, Sweden, Switzerland and United Kingdom.



EUROPEAN COMMITTEE FOR STANDARDIZATION
COMITÉ EUROPÉEN DE NORMALISATION
EUROPÄISCHES KOMITEE FÜR NORMUNG

Management Centre: rue de Stassart, 36 B-1050 Brussels

Foreword

The text of ISO 15025:2000 has been prepared by Technical Committee ISO/TC 94 "Personal safety - Protective clothing and equipment" of the International Organization for Standardization (ISO) and has been taken over as EN ISO 15025:2002 by Technical Committee CEN/TC 162 "Protective clothing including hand and arm protection and lifejackets", the secretariat of which is held by DIN.

This European Standard shall be given the status of a national standard, either by publication of an identical text or by endorsement, at the latest by May 2003, and conflicting national standards shall be withdrawn at the latest by May 2003.

This document supersedes EN 532:1994.

This document has been prepared under a mandate given to CEN by the European Commission and the European Free Trade Association, and supports essential requirements of EU Directive(s).

For relationship with EU Directive(s), see informative Annex ZA, which is an integral part of this document.

According to the CEN/CENELEC Internal Regulations, the national standards organizations of the following countries are bound to implement this European Standard: Austria, Belgium, Czech Republic, Denmark, Finland, France, Germany, Greece, Iceland, Ireland, Italy, Luxembourg, Malta, Netherlands, Norway, Portugal, Spain, Sweden, Switzerland and the United Kingdom.

Endorsement notice

The text of ISO 15025:2000 has been approved by CEN as EN ISO 15025:2002 without any modifications.

INTERNATIONAL
STANDARD

ISO
15025

First edition
2000-05-01

**Protective clothing — Protection against
heat and flame — Method of test for limited
flame spread**

*Vêtements de protection — Protection contre la chaleur et les flammes —
Méthode d'essai pour la propagation de flamme limitée*



Reference number
ISO 15025:2000(E)

Contents

Page

Foreword	iv
Introduction	v
1 Scope	1
2 Terms and definitions	1
3 Principle	2
4 Health and safety of test operators	2
5 Reagents	2
6 Apparatus	2
7 Sampling and sample preparation	7
7.1 Sampling	7
7.2 Conditioning atmosphere of the test sample	8
8 Procedure	8
8.1 Installation of the test apparatus	8
8.2 Test	10
9 Precision	11
10 Test report	11
Annex A (normative) Description and construction of the burner	13
Annex B (informative) Experimental techniques	14
Annex C (normative) Measurement of char length	15
Bibliography	16

Foreword

ISO (the International Organization for Standardization) is a worldwide federation of national standards bodies (ISO member bodies). The work of preparing International Standards is normally carried out through ISO technical committees. Each member body interested in a subject for which a technical committee has been established has the right to be represented on that committee. International organizations, governmental and non-governmental, in liaison with ISO, also take part in the work. ISO collaborates closely with the International Electrotechnical Commission (IEC) on all matters of electrotechnical standardization.

International Standards are drafted in accordance with the rules given in the ISO/IEC Directives, Part 3.

Draft International Standards adopted by the technical committees are circulated to the member bodies for voting. Publication as an International Standard requires approval by at least 75 % of the member bodies casting a vote.

Attention is drawn to the possibility that some of the elements of this International Standard may be the subject of patent rights. ISO shall not be held responsible for identifying any or all such patent rights.

International Standard ISO 15025 was prepared by Technical Committee ISO/TC 94, *Personal safety — Protective clothing and equipment*, Subcommittee SC 13, *Protective clothing*.

Annexes A and C form a normative part of ISO 15025. Annex B is for information only.

Introduction

This International Standard was initially prepared by Technical Committee ISO/TC38/SC19 as part of the revision of ISO 6940 and ISO 6941. This specific work item was transferred to Technical Committee ISO/TC 94/SC 13 in April 1997.

This method of test is closely related to the method of test specified in ISO 6941. It uses the same basic equipment but a smaller specimen holder and template. Materials which do not burn to the upper or vertical edges of the smaller test specimen used in this test may be classified as producing limited flame spread.

This method assesses the properties of textile fabrics in response to a short contact with a small igniting flame under controlled conditions. Results may not apply to situations where there is restricted air supply or exposure to large sources of intense heat.

The influence of seams on the behaviour of fabrics can be determined by this method, the seam being positioned within the test specimen so as to be subjected to the test flame.

Whenever practicable, trimmings should be tested as part of the fabric assembly on which they are or will be used.

A list of standards related to ISO 15025 is given in the Bibliography.

Protective clothing — Protection against heat and flame — Method of test for limited flame spread

1 Scope

This International Standard specifies a method for the measurement of limited flame spread properties of vertically oriented textile fabrics and industrial products in the form of single or multi-component fabrics (coated, quilted, multilayered, sandwich constructions, and similar combinations), when subjected to a small defined flame.

This test method is not appropriate for materials that demonstrate extensive melting or shrinkage.

2 Terms and definitions

For the purposes of this International Standard the following terms and definitions apply.

2.1

flame application time

time for which the ignition flame is applied to the test specimen

2.2

afterflame time

duration of flame

length of time for which a material continues to flame, under the specified test conditions, after the ignition source has been removed

NOTE Afterflame time is measured to the nearest second and afterflame times of less than 1,0 s should be recorded as zero.

2.3

afterglow

persistence of glowing combustion of a material under specified test conditions, after cessation of flaming or, if no flaming occurs, after removal of the ignition source

NOTE Afterglow is a continuation of combustion with the evolution of heat and light but without flame. Some materials absorb heat during the flame application and continue to emit this absorbed heat after removal of the igniting flame. This glowing without combustion should not be recorded as afterglow.

2.4

afterglow time

duration of afterglow

time for which a material continues to afterglow, under specified test conditions after cessation of flaming or after removal of the ignition source

NOTE Afterglow time is measured to the nearest second and afterglow times of less than 1,0 s should be recorded as zero.

2.5

char

formation of a brittle residue when material is exposed to thermal energy

EN ISO 15025:2002

2.6

debris

material separating from the specimen during the test procedure and falling from the specimen without flaming

2.7

flaming debris

material separating from the specimen during the test procedure and igniting the filter paper

2.8

hole

(surface ignition of procedure A) break in the test specimen of at least 5 mm in any dimension and having a continuous perimeter caused by melting, glowing or flaming

NOTE 1 If the hole is crossed by any material it is described as discontinuous.

NOTE 2 This International Standard describes the reporting of holes in any separable layer of a multilayer specimen obtained during surface ignition testing [see 8.2.1.3 g) and 10 i)].

3 Principle

A defined flame from a specified burner is applied for 10 s to the surface or the bottom edge of textile specimens which are vertically oriented.

Information is recorded on the spread of flame and afterglow, and on the formation of debris, flaming debris, or a hole. Afterflame time and afterglow time are recorded.

NOTE 1 Surface exposure tests may be performed on both sides of multilayer fabric assemblies.

NOTE 2 The bottom-edge ignition test may not offer acceptable reproducibility for testing some materials.

4 Health and safety of test operators

Burning of materials may produce smoke and toxic gases which can affect the health of operators. Between tests, the atmosphere of the test location, which should be of adequate dimensions to avoid endangering the health of operators, should be cleared of smoke and fumes by an extractor fan or other means of ventilation (see 6.1).

NOTE Smoke and fume emission may be subject to national regulations concerning atmospheric pollution control.

5 Reagents

5.1 **Gas**, of commercial grade, either propane or butane or butane/propane mixtures.

NOTE Commercial grade propane is preferred but other gases may be used and this fact recorded in the test report (see item b) in clause 10.

6 Apparatus

6.1 Test apparatus — General requirements

— Construction: consisting of material which shall not be adversely affected by the fumes and that is resistant to heat and flame.

NOTE Some products of combustion are corrosive.

- Location: surrounded by a volume of air sufficient not to be affected by any reduction of oxygen concentration. Where an open-fronted cabinet is used for the test, provision shall be made to permit the specimen to be mounted at least 300 mm from any wall.

6.2 Mounting frame, constructed to a design capable of holding the test specimen holder (see 6.4 and Figure 1) and the gas burner (see 6.3 and Figure 2) in the specified relative orientation (see Figure 3).

6.3 Gas burner, as described in annex A (see Figure 2), capable of being moved from a standby position, where the tip of the burner is at least 75 mm from the test specimen, to either the horizontal or inclined operating position [see Figure 3 a) and 3 b) respectively].

Dimensions in millimetres

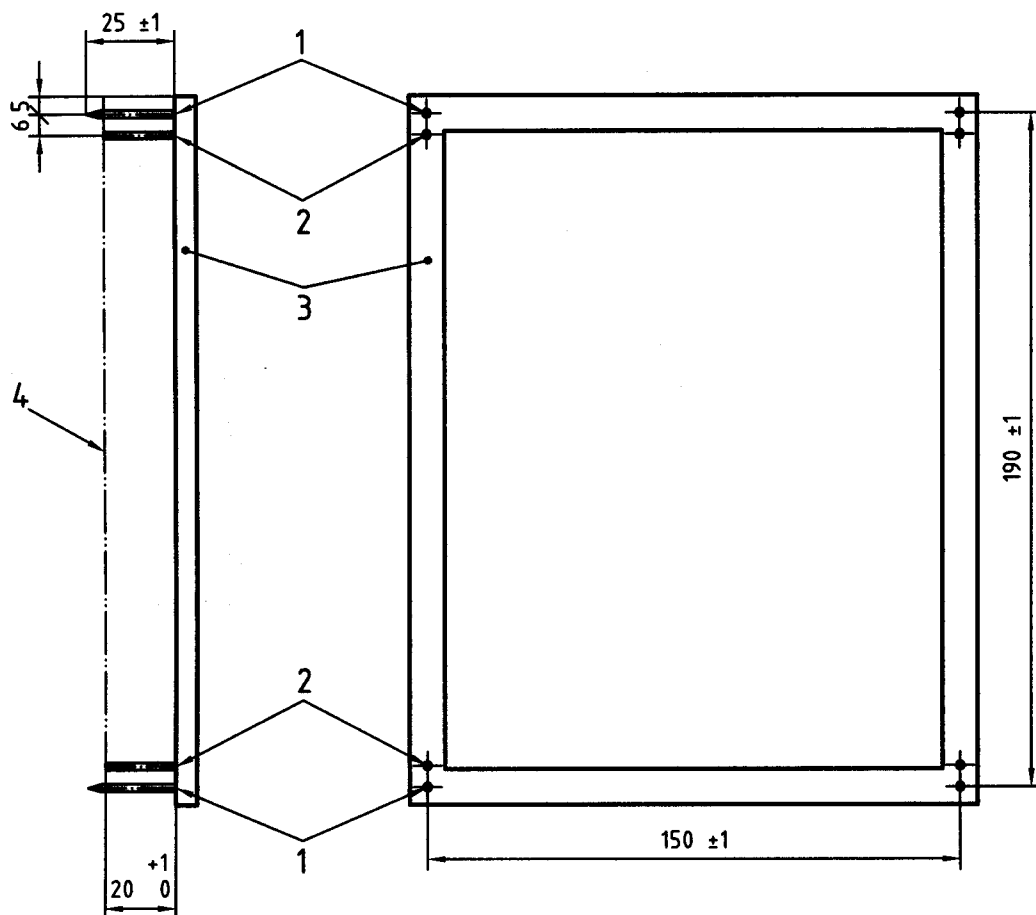

Key

- 1 Specimen support pin, ($2 \pm 0,5$) mm diameter
- 2 Spacer stub, 2 mm diameter
- 3 Mounting frame
- 4 Specimen

Figure 1 — Test specimen holder

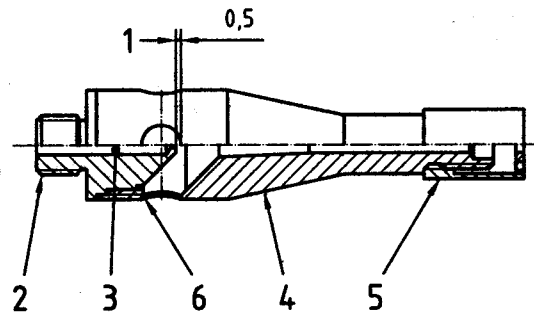

a) Gas burner arrangement

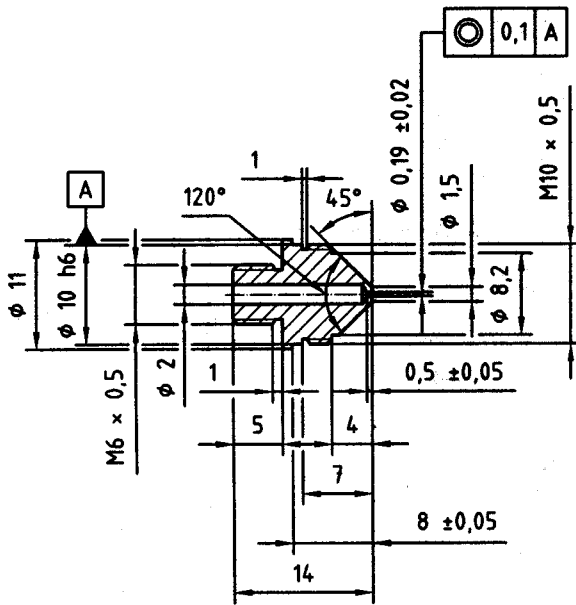

b) Gas jet

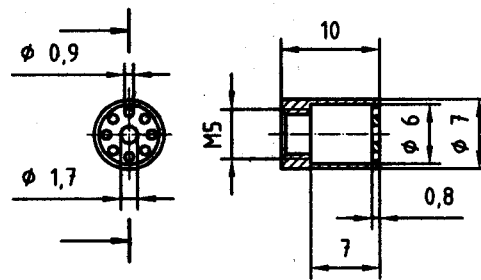

c) Flame stabilizer

Key

- 1 Fitted in during assembly
- 2 Gas jet
- 3 Choke tube
- 4 Burner tube
- 5 Flame stabilizer
- 6 Notch

Figure 2 — Gas burner

Dimensions in millimetres

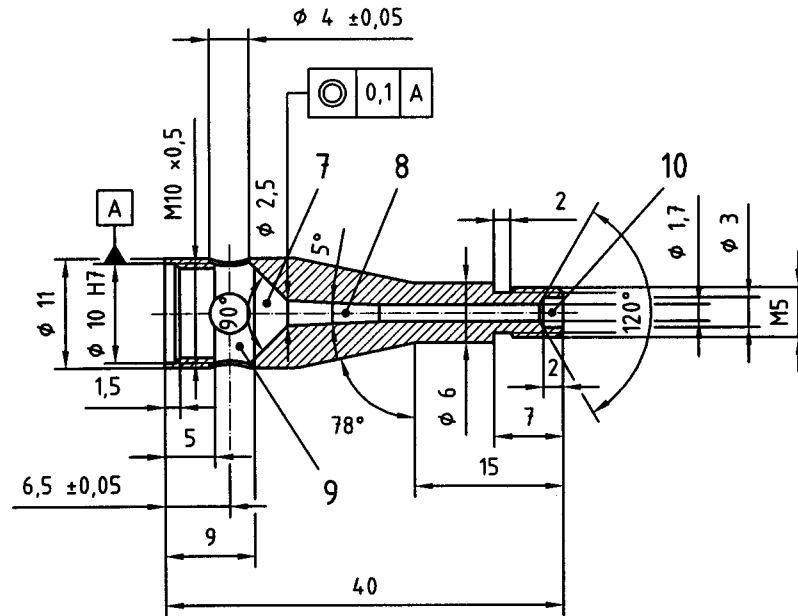

d) Burner tube

Key

- 7 Gas-mixing zone
- 8 Diffusion zone
- 9 Air chamber
- 10 Outlet

Figure 2 — Gas burner (continued)

Dimensions in millimetres

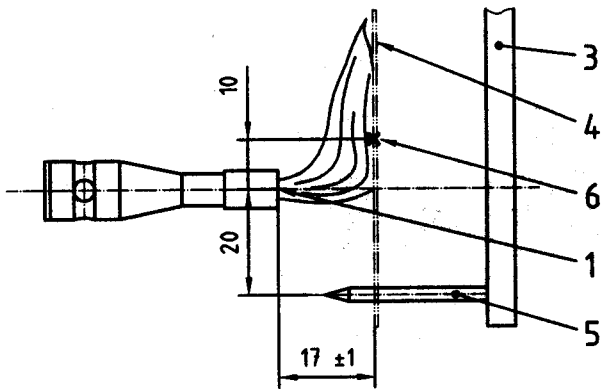

a) Face ignition

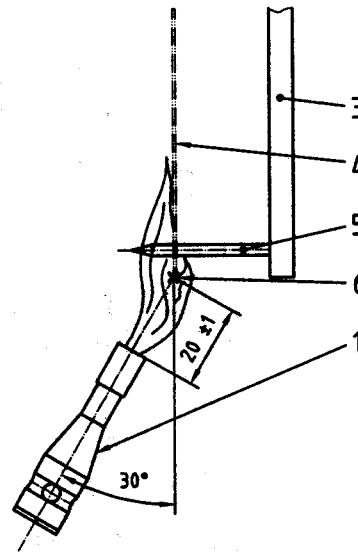

b) Bottom-edge ignition

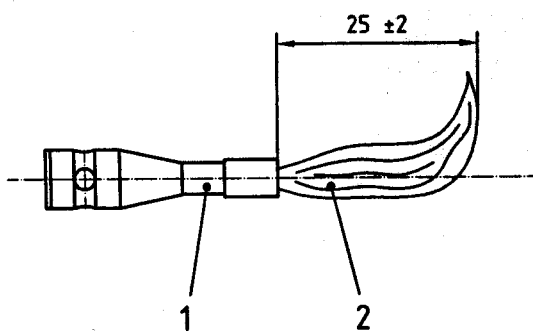

c) Horizontal stand-by position, horizontal reach adjustment

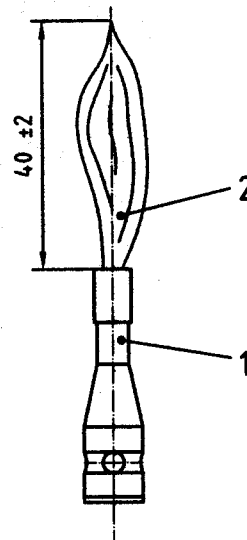

d) Vertical stand-by flame height

Key

- 1 Burner
- 2 Flame
- 3 Mounting frame
- 4 Specimen
- 5 Mounting pin
- 6 Nominal flame application point

Figure 3 — Flame position and adjustment

6.4 Specimen holder, consisting of a rectangular metal frame having a specimen support pin at each corner of a rectangle of 190 mm length by 150 mm width (see Figure 1).

6.4.1 Supporting pins, for the specimen having a $(2 \pm 0,5)$ mm diameter and a length of (25 ± 1) mm.

NOTE Longer pins may be needed for mounting thick or multilayer specimens.

6.4.2 Spacer stub, for the purpose of locating the specimen in a plane at least 20 mm away from the frame (see 8.1.2.1 and 8.1.3.1), of 2 mm diameter and a length of at least 20 mm and positioned adjacent to each of the four pins.

6.5 Template, flat and rigid, made of a suitable material and of a size corresponding to the size of the specimen (200 mm \times 160 mm).

Holes approximately 4 mm in diameter shall be drilled in each corner of the template and positioned so that the distances between the centres of the holes correspond to the distances between the pins on the specimen holder (see Figure 1). The holes shall be located equidistant about the vertical centreline of the template.

6.6 Timing devices:

— One timing device to control and measure the flame application time, which can be set at 1 s intervals with an accuracy of 0,2 s or better.

— Two timing devices reading to 0,2 s or better are required to measure the afterflame time and/or afterglow time. These devices are started, preferably automatically, at the instant of test flame termination or removal, and are stopped manually.

NOTE Alternatively, a video recording of the test can be made, provided that an on-screen timer is provided with the specified precision.

6.7 Filter paper, with the following characteristics:

- area specific mass: 60 g/m² to 100 g/m²
- size: $\geq (150 \text{ mm} \times 100 \text{ mm})$
- thickness: 0,15 mm to 0,25 mm
- alpha cellulose content: $\geq 95 \%$.

7 Sampling and sample preparation

7.1 Sampling

7.1.1 Number of specimens

Using the template (6.5), mark two sets of three test specimens. Mark one set perpendicular to the other. For woven/knitted or similar materials, orient the lengthwise axis of the template in the machine and cross-machine direction.

For surface ignition, where the two surfaces of the sample are visually dissimilar and preliminary testing indicates dissimilar flammability characteristics, each surface shall be tested by the use of a set of six specimens.

An extra test specimen is required for the installation procedure (see 8.1.2 and 8.1.3).

EN ISO 15025:2002

7.1.2 Specimen-holder pin location marks

Mark the position through which the pins on the specimen holder shall pass by means of the holes in the template (6.5).

NOTE Where the fabric is of open construction (for instance scrim, gauze), small pieces of adhesive tape may be affixed to the fabric at the pin sites and the position marked on the tape.

7.1.3 Test specimen size

Cut out test specimens with dimensions of (200 ± 2) mm \times (160 ± 2) mm.

7.1.4 Multilayer specimens

When specimens are composed of multiple layers or materials that are not continuous over the entire specimen, position the material of the smaller dimension along the bottom edge of the specimen, in a manner consistent with its use in the protective clothing, including the manner of attachment and orientation.

EXAMPLE Specimens containing retroreflective tape or emblems and lettering are typical examples of multilayer specimens where this specimen preparation procedure should be used.

7.2 Conditioning atmosphere of the test sample

Unless otherwise specified, test specimens shall be conditioned in an atmosphere having a temperature of (20 ± 2) °C and a relative humidity of (65 ± 5) % for at least 24 h. If testing is not carried out immediately after conditioning, place the conditioned test specimens in a sealed container. Testing of each specimen shall begin within 2 min of removing it from either the conditioning atmosphere or the sealed container.

NOTE Care should be taken to avoid injury when mounting the specimens on the pins in the time specified. If necessary, the specimen may be mounted on the specimen holder (6.4) before removal from the conditioning atmosphere.

8 Procedure

NOTE More practical information concerning the experimental aspects of this technique are given in annex B.

8.1 Installation of the test apparatus

8.1.1 Test conditions

The tests shall be performed in an atmosphere having a temperature between 10 °C and 30 °C, a relative humidity between 15 % and 80 %, and air movement less than 0,2 m/s at the commencement of the test of each specimen. Air movement shall not be influenced by mechanical devices operating during the test.

NOTE Draught shields may be required to maintain stability of the test flame.

8.1.2 Procedure A — Surface ignition

8.1.2.1 Mounting of the test specimen

Place the test specimen (see 7.1.1) on the pins of the test specimen holder, making certain that the pins pass through the points marked off from the template and that the back of the specimen is at least 20 mm away from the rectangular metal frame of the test specimen holder. Fit the test specimen holder to the mounting frame with the specimen vertical.

8.1.2.2 Operating position of the burner

Position the burner (6.3) perpendicular to the surface of the test specimen so as to align the axis of the burner 20 mm above the line of the lower pins and with the vertical centreline of the face of the test specimen. Make sure that the tip of the burner stabilizer is (17 ± 1) mm from the surface of the test specimen [see Figure 3 a)].

8.1.2.3 Flame adjustment — Horizontal reach

Set the burner (6.3) in the vertical standby position. Light the burner and preheat it for at least 2 min. Move the burner into the horizontal standby position and adjust the horizontal reach of the flame to (25 ± 2) mm measured as the distance from the tip of the burner stabilizer to the extreme end of the yellow part of flame when viewed against a dark background [see Figure 3 c)].

The flame reach shall be checked before testing each set of six specimens.

If the apparatus does not have a horizontal standby position, it shall be necessary to remove the test specimen before carrying out the flame adjustment.

8.1.2.4 Flame position

Move the burner from the standby position to the horizontal operating position (see 8.1.2.2). Confirm that the flame impinges on the test specimen in the correct location [see Figure 3 a)]. Test all six specimens within a total of 10 min from completion of the preheat procedure and flame adjustment (8.1.2.3).

8.1.2.5 Debris

If debris is observed during the installation test, the additional procedure of 8.1.4 shall be used for subsequent testing, to determine whether the debris is to be termed flaming debris.

8.1.3 Procedure B — Bottom-edge ignition

8.1.3.1 Mounting of the test specimen

Place the test specimen (see 7.1) on the pins of the test specimen holder, making certain that the pins pass through the points marked off from the template and that the back of the specimen is at least 20 mm away from the rectangular metal frame of the test specimen holder. Fit the test specimen holder to the mounting frame with the specimen vertical.

8.1.3.2 Operating position of the burner

Position the burner in front of, but below, the test specimen so as to lie in a plane passing through the vertical centreline of the test specimen and perpendicular to its surface with the longitudinal axis inclined upwards at a 30° angle to the vertical bottom edge of the test specimen. Make sure that the distance between the tip of the burner stabilizer and the bottom edge of the test specimen is (20 ± 1) mm, measured as shown in Figure 3 b).

NOTE It may not be possible to obtain consistent results with fabrics which exhibit drape or sag. Surface ignition may be more appropriate for such fabrics.

8.1.3.3 Flame adjustment — Vertical flame height

Set the burner (6.3) in the vertical standby position. Light the burner and preheat it for at least 2 min. Adjust the flame height to (40 ± 2) mm, measured as the distance from the tip of the burner stabilizer to the extreme end of the yellow part of flame when viewed against a dark background [see Figure 3 d)].

The flame height shall be checked before testing each set of six specimens.

EN ISO 15025:2002

8.1.3.4 Flame position

Move the burner from the standby position to the inclined operating position (see 8.1.3.2). Check that the bottom edge of the test specimen bisects the flame [see Figure 3 b)].

8.1.3.5 Debris

If debris is observed during the installation test, the additional procedure of 8.1.4 shall be used for subsequent testing to determine whether the debris is to be termed flaming debris.

8.1.4 Detection of flaming debris

If debris is observed in the installation procedure (8.1.2.5 or 8.1.3.5) or in subsequent testing, the following additional procedure shall be employed to determine if the debris is to be classified as flaming debris.

A piece of filter paper (6.7), at least (150 × 100) mm shall be placed on a horizontal solid surface (50 ± 5) mm below the bottom edge of the specimen with the centre of the filter paper directly below the centreline of the specimen.

NOTE If the burner mechanism touches the filter paper when using bottom-edge ignition, a suitable slot should be cut in the mounting plate and in each piece of filter paper used.

8.2 Test

8.2.1 Surface ignition

8.2.1.1 Set up the apparatus as described in 8.1.2.

8.2.1.2 Position test specimen on the specimen holder (see 8.1.2.1). For woven/knitted materials, record whether the machine or cross machine direction is vertical.

8.2.1.3 Apply the test flame for 10 s and observe and record:

- a) whether any flaming reaches the upper edge or either vertical edge of the test specimen;
- b) afterflame time;
- c) whether afterglow spreads beyond the flame spread area (usually the carbonized area) into the undamaged area;
- d) afterglow time;
- e) the occurrence of debris;
- f) whether debris ignites the filter paper (flaming debris), if applicable;
- g) whether a hole develops, and in which layer(s) for a multilayer specimen.

NOTE When testing multilayer specimens, a hole formation should be reported in each separable layer.

8.2.1.4 Repeat 8.2.1.2 and 8.2.1.3 on the remaining five test specimens, with the same surface of all specimens exposed towards the flame.

8.2.2 Bottom-edge ignition

8.2.2.1 Set up the apparatus as described in 8.1.3.

8.2.2.2 Position the first of a set of six fresh test specimens on the specimen holder. For woven/knitted materials, record whether the machine or cross machine direction is vertical.

8.2.2.3 Apply the test flame for 10 s and observe and record behaviour as listed in 8.2.1.3, with the exception of g) which is not applicable to bottom-edge ignition. When elected, measure char length using the procedure in annex C.

NOTE The measurement of char length is optional. Some laboratories have reported that when using the bottom-edge ignition test it can be difficult to obtain consistent interlaboratory results for the measurement of the char length.

8.2.2.4 Repeat 8.2.2.2 and 8.2.2.3 on the remaining five test specimens, with the same surface of all specimens exposed towards the flame.

9 Precision

These methods are used to determine whether or not flame spread to the edge of the specimen occurs. They consistently detect two groups of fabrics:

- fabrics which give little or no afterflame and
- fabrics which burn completely.

However, there are some intermediate fabrics which can demonstrate more extensive, but not complete, flame spread under specific circumstances. These intermediate fabrics can give widely scattered results from one specimen to another and may give different results with different test procedures, for instance surface or bottom-edge ignition, and in different laboratories.

An interlaboratory trial with eleven fabrics in six laboratories was carried out in 1990. Using surface ignition, ten of the fabrics tested gave zero or very short afterflame times (< 3 s) and no afterglow. The remaining fabric consistently gave long but variable (from 8 s to 17 s) afterflame times without burning to the edge. Using bottom-edge ignition only eight of the fabrics gave consistent, low afterflame times (< 2 s). The remaining three fabrics gave longer afterflame times, which varied considerably from one specimen to another, but only in some laboratories.

On the fabrics included in this trial, the face ignition test (procedure A) gave consistent results whilst the bottom-edge ignition test (procedure B) detected inconsistent intermediate behaviour on some fabrics in some laboratories only.

10 Test report

The test report shall include the following information:

- a) a statement that the test was carried out in accordance with this International Standard, i.e. ISO 15025, and details of any deviation from it;
- b) the type of gas used;
- c) the date of test;
- d) the ambient conditions of temperature and relative humidity in the area in which the test is carried out (see 8.1.1);
- e) the technique used to attach fabrics which cannot be supported on pins (see 7.1.2);
- f) an identification of the fabric tested including details of any pretreatment, for instance a cleansing procedure;

EN ISO 15025:2002

- g) the type of surface exposed towards the flame and the type of ignition used, i.e. surface or bottom-edge ignition;
- h) for each test specimen the information itemized in 8.2.1.3 as required by the appropriate performance specification;
- i) an indication of the layers developing holes during the surface ignition test as required in 8.2.1.3 for multilayer specimens.

Annex A (normative)

Description and construction of the burner

A.1 Description

The burner¹⁾ provides a flame of suitable dimensions, the length of which can be adjusted from 10 mm to 60 mm.

A.2 Construction

The construction of the burner is shown in Figure 2 a). The burner consists of three parts:

A.2.1 Gas jet

The orifice diameter of the gas jet [see Figure 2 b)] shall be $(0,19 \pm 0,02)$ mm. The orifice shall be drilled and after drilling, all burrs shall be removed from both ends of the drilled hole without rounding the corners.

A.2.2 Burner tube

The burner tube [see Figure 2 d)] consists of four zones:

- a) air chamber;
- b) gas-mixing zone;
- c) diffusion zone;
- d) gas outlet.

Within the air chamber, the burner tube has four air holes 4 mm diameter for air inlet. The forward edge of the air holes is approximately level with the tip of the jet.

The diffusion zone is of conical shape and has the dimensions indicated in Figure 2 d). The burner has a bore of 1,7 mm internal diameter and an outlet of 3,0 mm internal diameter.

A.2.3 Flame stabilizer

The flame stabilizer is given in detail in Figure 2 c).

¹⁾ Details of the availability of the specified burner may be obtained from the secretariat of ISO/TC 38/SC 19, American Textile Manufacturers Institute, 1130 Connecticut Ave., NW, Suite 1200, Washington D.C. 20036-3954, USA.

Annex B (informative)

Experimental techniques

The quality of the experimental techniques required will depend to a significant extent on the design of the equipment used. For example, the poorer the automation of the equipment, the greater the need will be for a more skilled operator to perform the test in order to obtain high precision.

Some practical points of a general nature are as follows:

- a) For reasons of safety, the test equipment should be remote from the gas cylinder which can be located outside the building. In this case, a manually operated shut-off valve should be installed inside the room-housing of the test apparatus where the piping enters. On each occasion the equipment is used, time should be allowed for pure gas to reach the burner jet and provide a steady flame.

The equipment should be installed and used in a manner to prevent smouldering particles, which may be carried away by hot gases or fall from the specimen, from coming to rest on combustible materials. Protective clothing, fire extinguishers and alarm signals should be available to the operator.

- b) It is important to keep the apparatus clean to maintain safety.
- c) Some unfinished fabrics, such as single knit-jersey knitted fabrics, are liable to curl. This tendency may be reduced by subsequent processing. It is desirable to test this type of fabric in its finished state.
- d) Residual material adhering to the pins after testing may be removed by scraping with a wire brush. Any smouldering material shall be extinguished before placing it with other waste in a non-combustible container.
- e) Preliminary tests should be undertaken to establish if one surface of the fabric under examination is likely to produce different flammability behaviour from the other. If they are different, the worst or both surfaces should be tested.

Annex C (normative)

Measurement of char length

The char length shall be the distance from the end of the specimen when it is exposed to the flame, to the end of a tear (made lengthwise) of the specimen through the centre of the charred area determined as follows:

The test specimen shall be folded lengthwise and creased by hand along a line through the highest peak of the charred area. A hook, made of steel wire, using a 76 mm length of wire and bent 13 mm from one end to form a 45° hook, shall be inserted into the specimen (or a hole of 6 mm diameter or less pinched out for the hook) at one side of the charred area 6 mm from the adjacent outside edge and 60 mm from the lower end weight of sufficient mass is required such that the mass of the weight and hook together shall equal the total tearing load required.

A tearing force shall be applied gently to the test specimen by grasping the corner of the specimen at the opposite edge of the char from the load, and raising the specimen and weight clear of the supporting surface. The end of the tear shall be marked on the edge and the char length measurement made along the undamaged edge.

The specific load applicable to the mass of the test specimen is given in Table C.1

Table C.1

Mass of test specimen material before any fire retardant or coating g/m ²	Total tearing load for determining the char length kg
50 to 200	0,1
Over 200 to 500	0,2
Over 500 to 800	0,3
Over 800	0,45

Bibliography

- [1] ISO 6940, *Textile fabrics — Burning behaviour — Determination of ease of ignition of vertically oriented specimens.*
- [2] ISO 6941, *Textile fabrics — Burning behaviour — Measurement of flame spread properties of vertically oriented specimens.*

Annex ZA
(informative)

Clauses of this European Standard addressing essential requirements or other provisions of EU Directives

This European Standard has been prepared under a mandate given to CEN by the European Commission and the European Free Trade Association and supports essential requirements of EU Directive 89/686/EEC.

WARNING Other requirements and other EU Directives may be applicable to the product(s) falling within the scope of this standard.

"The clauses of this European Standard specify test methods for the relevant requirements of protective clothing to support the essential requirements of Directive 89/686/EEC, Annex II, clause 3.6.1"

Compliance with these clauses of this standard provides one means of conforming with the specific essential requirements of the Directive concerned and associated EFTA regulations.

BSI — British Standards Institution

BSI is the independent national body responsible for preparing British Standards. It presents the UK view on standards in Europe and at the international level. It is incorporated by Royal Charter.

Revisions

British Standards are updated by amendment or revision. Users of British Standards should make sure that they possess the latest amendments or editions.

It is the constant aim of BSI to improve the quality of our products and services. We would be grateful if anyone finding an inaccuracy or ambiguity while using this British Standard would inform the Secretary of the technical committee responsible, the identity of which can be found on the inside front cover.
Tel: +44 (0)20 8996 9000. Fax: +44 (0)20 8996 7400.

BSI offers members an individual updating service called PLUS which ensures that subscribers automatically receive the latest editions of standards.

Buying standards

Orders for all BSI, international and foreign standards publications should be addressed to Customer Services. Tel: +44 (0)20 8996 9001.
Fax: +44 (0)20 8996 7001. Email: orders@bsi-global.com. Standards are also available from the BSI website at <http://www.bsi-global.com>.

In response to orders for international standards, it is BSI policy to supply the BSI implementation of those that have been published as British Standards, unless otherwise requested.

Information on standards

BSI provides a wide range of information on national, European and international standards through its Library and its Technical Help to Exporters Service. Various BSI electronic information services are also available which give details on all its products and services. Contact the Information Centre.
Tel: +44 (0)20 8996 7111. Fax: +44 (0)20 8996 7048. Email: info@bsi-global.com.

Subscribing members of BSI are kept up to date with standards developments and receive substantial discounts on the purchase price of standards. For details of these and other benefits contact Membership Administration.
Tel: +44 (0)20 8996 7002. Fax: +44 (0)20 8996 7001.
Email: membership@bsi-global.com.

Information regarding online access to British Standards via British Standards Online can be found at <http://www.bsi-global.com/bsonline>.

Further information about BSI is available on the BSI website at <http://www.bsi-global.com>.

Copyright

Copyright subsists in all BSI publications. BSI also holds the copyright, in the UK, of the publications of the international standardization bodies. Except as permitted under the Copyright, Designs and Patents Act 1988 no extract may be reproduced, stored in a retrieval system or transmitted in any form or by any means – electronic, photocopying, recording or otherwise – without prior written permission from BSI.

This does not preclude the free use, in the course of implementing the standard, of necessary details such as symbols, and size, type or grade designations. If these details are to be used for any other purpose than implementation then the prior written permission of BSI must be obtained.

Details and advice can be obtained from the Copyright & Licensing Manager.
Tel: +44 (0)20 8996 7070. Fax: +44 (0)20 8996 7553.
Email: copyright@bsi-global.com.

BSI
389 Chiswick High Road
London
W4 4AL